

CUSTOMER NAME _____ Qty of Cylinders _____ Double Acting _____ Single Acting _____

Cylinder Application _____ Number of Stages _____

Cylinder Capacity: _____ Mounting Conditions
CYLINDER PUSH REQUIREMENT _____ (lbs) Vert _____ Horiz _____

CYLINDER PULL REQUIREMENT _____ (lbs) Incline Angle _____

Ports	Size & Type	Location
Extend:		
Retract:		

Cylinder Key Dimension

(Lug Style Connections Shown for Illustration Purposes only)

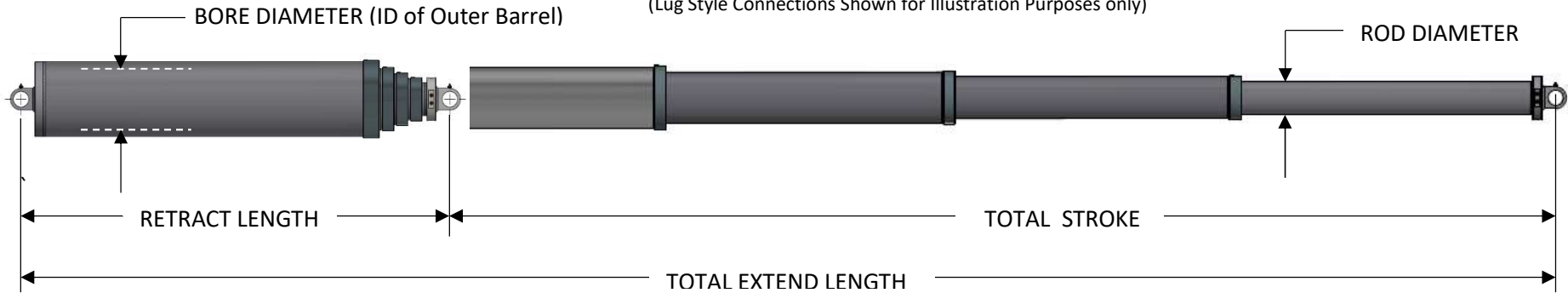

Inside Diameter of Outer Barrel _____ (in) Rod (Smallest) Diameter _____ (in) Retract Length _____ (in) Total Extend Length _____ (in)
Total Stroke Length _____ (in) Working Pressure _____ (psi) Valves / Load Holding Requirement _____

Additional Information:

STYLE OF CYLINDER CONNECTIONS

Please circle type of Connection
Identify for Barrel End and/or Rod End
Provide Detailed Information Pin Diameter _____
Length Cross Tube or Spacing of Lugs _____
If other please specify _____

